



O-I Italy S.p.A.
Via 1° Maggio, 18
21040 Origgio(VA), Italy
Tel. +39 0243453.1

CONTAINER & MOULD DESIGN
EUROPE

NOTES:
THIS DRAWING IS THE PROPERTY OF O-I AND
MUST NOT BE REPRODUCED OR DISCLOSED
WITHOUT O-I WRITTEN AUTHORIZATION.

DIMENSIONS EXPRESSED IN mm
ONLY TOLERANCED DIMENSIONS ARE GUARANTEED.

MANUFACTURING MARKINGS SHOWN ARE FOR ILLUSTRATIVE
PURPOSES ONLY, ACTUAL MARKINGS ON CONTAINER
MAY DIFFER, DEPENDANT ON LOCAL LEGISLATION.

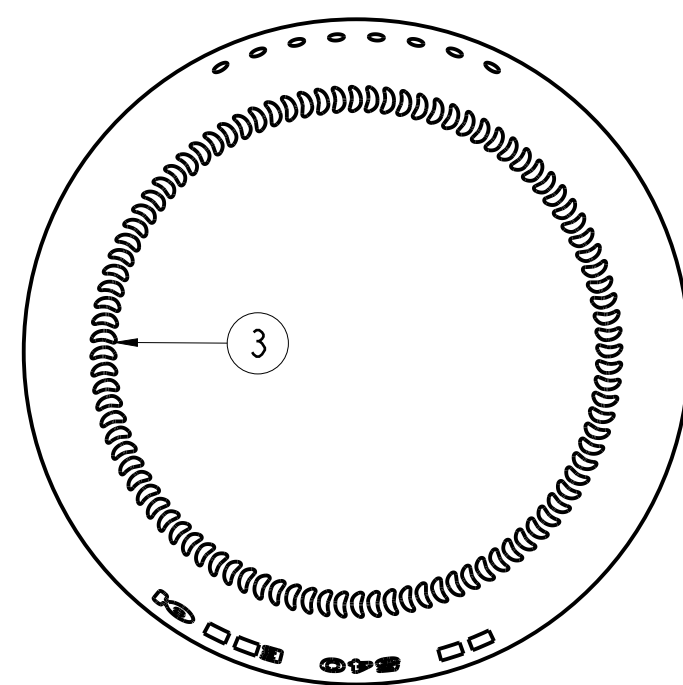
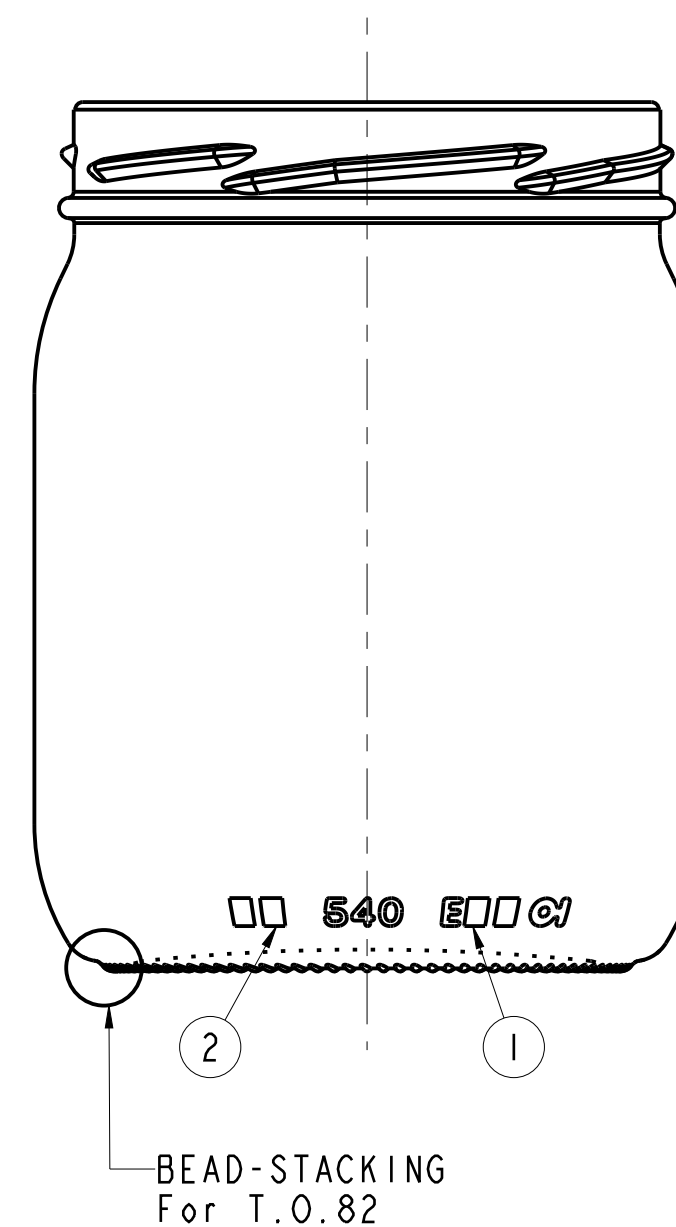
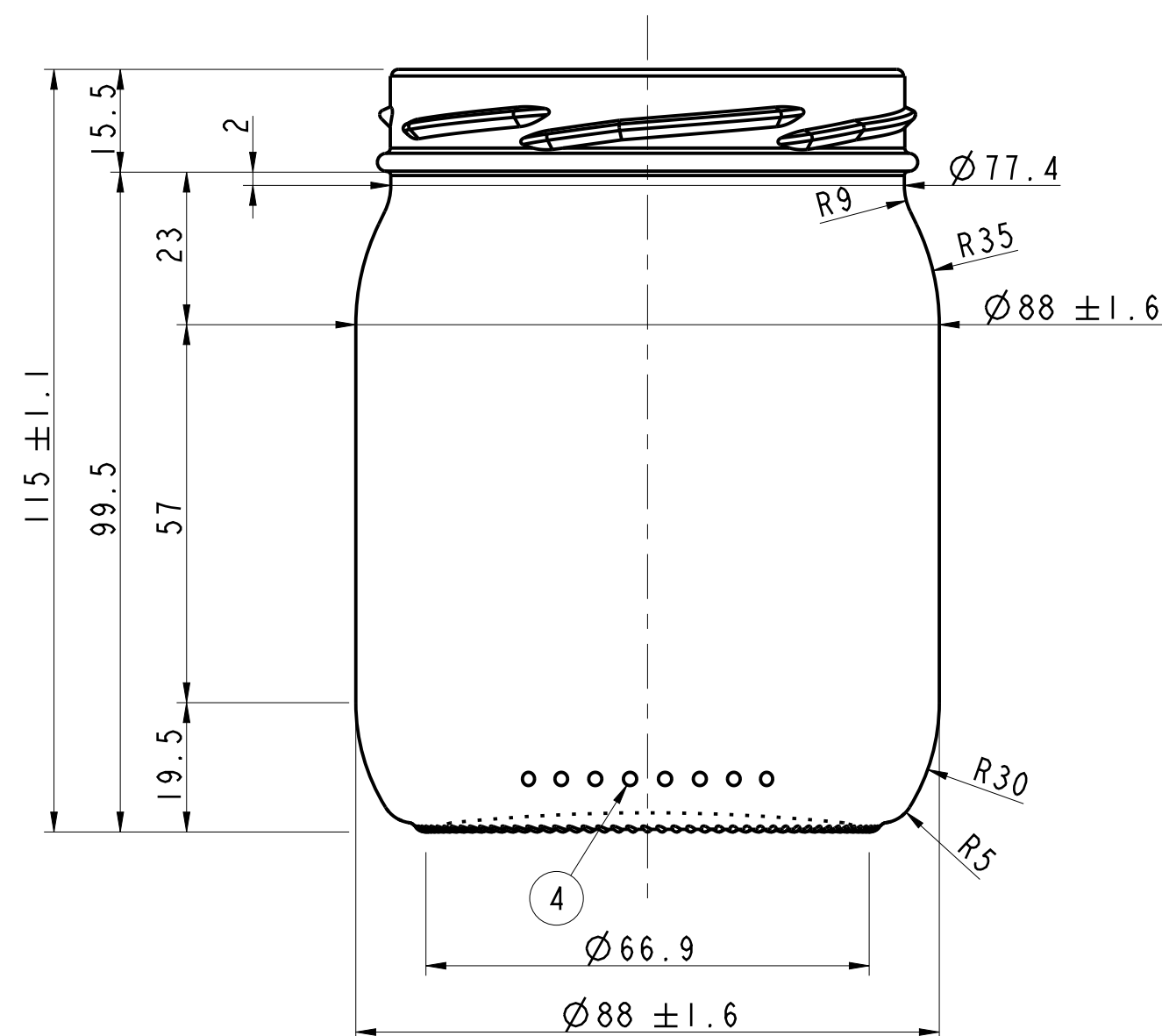

1 = TRADEMARK
2 = CAVITY No.
3 = STIPPLING
THE SHAPE OF STIPPLES IS ONLY AN
INDICATION AND THE CONSTRUCTION IS AT
THE PRODUCTION PLANT DISCRETION.
4 = CAVITY CODE

SCALE 1:1

CATEGORY FOOD	TILT ANGLE 31.87°
MAX. VERTICALITY TOLERANCE 1.27 mm	MEASURING CONTAINER NO
FINISH SAP NUMBER 0617	FINISH REF. SPECIAL
MINIMUM THROUGH BORE	MAX FILLING TUBE Ø
CONTAINER OVERFLOW CAPACITY (BRIMFUL)	
540ml ± 10ml	
CONTAINER RATED CAPACITY (FILLPOINT)	
CONTAINER WEIGHT	
260g APPROX.	
FINISH DESIGNATION PL_82_SPECIAL_H155_0617	
MAX GAS VOLUME	
PROCESS	RETURNABLE NO
DESIGN REF. JS-1550	

STANDARD
54 cl TO 82

DESIGNER	CD	DATE	05/08/19
CHECKED		DATE	
DRAWING NUMBER 190484		SHAPE NUMBER 006182	

No	DATE	REVISIONS	DESIGN/CHECK